

LAMVIN

Acoustical Products Manufacturer

760.806.6400

Drawing no.

15045

Project Name:

FIELD CUT AND REWRAP OF ACOUSTIC PANELS

Drawn by.

Jared

Date.

10/22/2015

Description:

An illustrated guide for cutting panels in the field

Revision.

1.0

Scale.

NTS

Panel Core

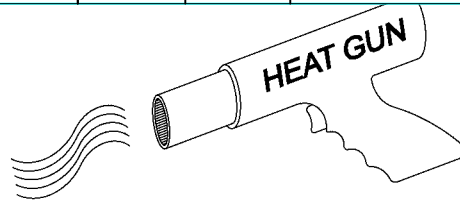
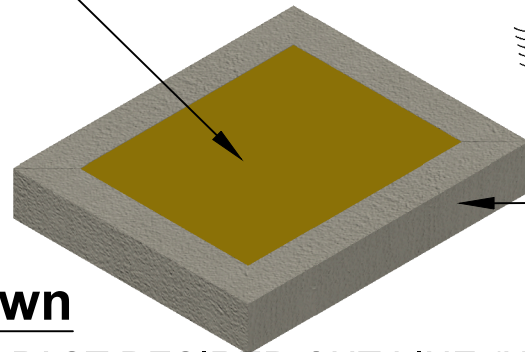

Fabric Wrap

Panel Face Down

PEEL FABRIC BACK PAST DESIRED CUT LINE (USE HEAT GUN TO AID IN THE RELEASE OF FABRIC FROM ADHESIVE)

Cut Line

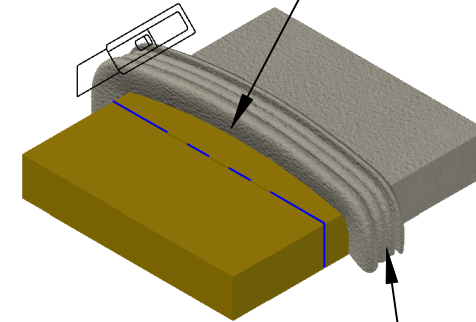

Peel Back Fabric

Panel Face Up

CUT PANEL, FACE UP, WITH A STRAIGHT EDGE OR RAZOR KNIFE (CARE SHOULD BE TAKE TO AVOID CUTTING FABRIC)

Shield panel from overspray using cardboard, etc.

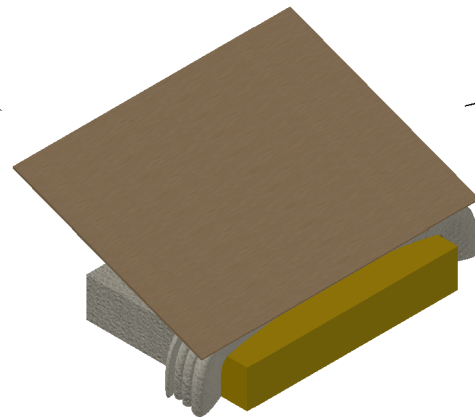

Panel Face Up

APPLY ADHESIVE TO EXPOSED PANEL CORE AND BACK OF FABRIC (ALL FIELD ALTERATIONS REQUIRE 1" FABRIC RETURN ON BACK OF PANEL)

Cut & Remove Flaps

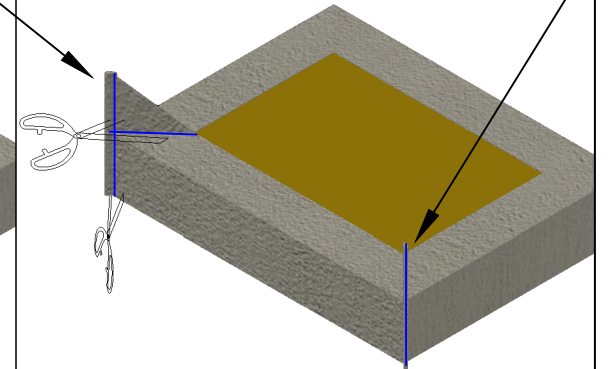
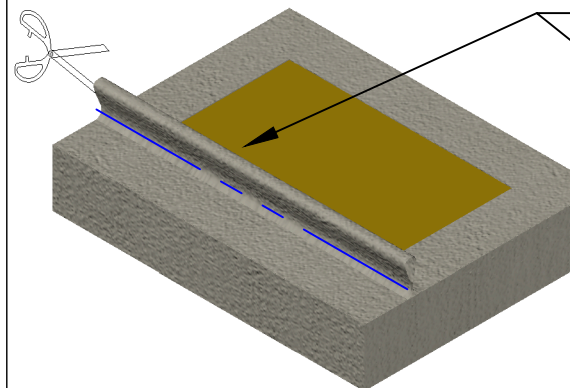

Panel Face Down

PINCH EXCESS FABRIC TOGETHER WITH FINGERS AND CUT OFF FLAPS WITH FABRIC SCISSORS

* Images shown are for illustration purposes only.