



LAMVIN®

SUBWAY™



SPECIFICATIONS

Panel Sizes: 23.5" w x 23.5" h or 47" w x 23.5" h

Thickness: 9mm

Edge Detail: Chamfered

Weight: .25 lbs/SF



FIRE RATING

Class A per ASTM E-84

COMPOSITION



- 100% Polyethylene Terephthalate (PET)
- 55% recycled content

ENVIRONMENTAL FACTORS



- 100% recyclable
- Low VOC Emissions
 - ASTM - D5116
 - LEED - MRc4

INSTALL METHODS:

Construction Panel Adhesive, Carpet Glue or Nail Clips with Adhesive

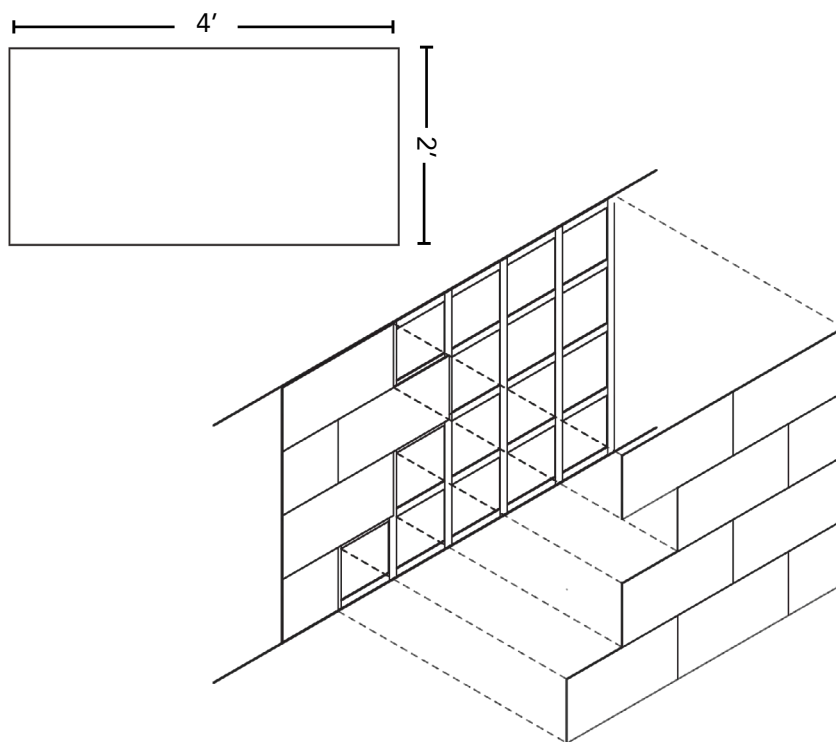

ACOUSTICAL DATA

Frequency (Hz)	125	250	500	1000	2000	4000	NRC
9mm Thickness	.04	.04	.16	.40	.63	.82	.30

Tested as Type "A" Mounting

LAMVIN

www.lamvin.com |     